

EURAX G 536

Phase angle or power factor transducer

EURAX plug-in module in Euro format



Application

The transducer **EURAX G 536** (Fig. 1) measures the phase angle or power factor between current and voltage of a single or 3-phase balanced network having a sine wave form.

The output signal, in the form of a **load independent** DC current or voltage, is proportional to the phase angle resp. power factor between the 2 measured quantities current and voltage.

The transducer fulfils all the important requirements and regulations concerning electromagnetic compatibility **EMV** and **Safety** (IEC 1010 resp. EN 61 010). It was developed and is manufactured and tested in strict accordance with the **quality assurance standard** ISO 9001.



Fig. 1. EURAX G 536 as plug-in module for 19" rack-mounted case, front plate width 7 TE.

Features / Benefits

- **Measuring input:** Sine, rectangular or distorted wave forms of input quantities with dominant fundamental waves

Measured variables	Nominal input current	Nominal input voltage	Measuring range limits
Phase angle or power factor	0.5 to 6 A	10 to 690 V	Min. span 20 °el Max. span 360 °el

- **Measuring output:** Unipolar, bipolar or live zero output variables
- **Measuring principle:** Measurement of the zero crossing interval
- **Wide DC, AC power pack tolerance / Universal**
- **Plug-in module (front plate width 7 TE) for 19" rack-mounted case / Ease of mounting in rack system**

Technical data

General

Measured quantity: Phase angle or power factor between current and voltage

Measuring principle: Measurement of the zero crossing interval

Measuring input \rightarrow

Examples of measuring ranges with φ -linear output

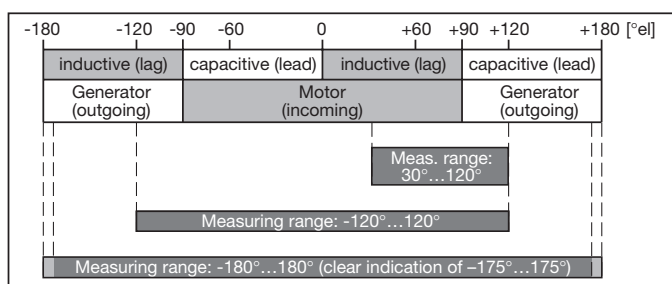

Examples of measuring ranges with $\cos\varphi$ -linear output

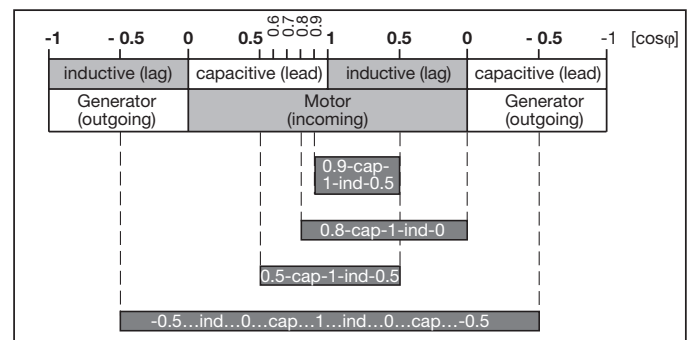

Nominal frequency f_N : 16 2/3 ... 400 Hz

Nominal input voltage U_N : 10 ... 690 V
(max. 230 V with power supply from voltage measuring input)

Response sensitivity: 10 ... 120% U_N

Nominal input current I_N : ≥ 0.5 to 6.0 A

Response sensitivity: $< 1\% I_N$

Own consumption: < 0.1 VA per current path
 $U_N \cdot 1.5$ mA per voltage path

Overload capacity:

Input variables I_N, U_N	Number of applications	Duration of one application	Interval between two successive applications
$1.2 \times I_N$	---	continuously	---
$20 \times I_N$	10	1 s	100 s
$1.2 \times U_N^1$	---	continuously	---
$2 \times U_N^1$	10	1 s	10 s

¹ But max. 264 V with power supply from voltage measurement

EURAX G 536

Phase angle or power factor transducer

Measuring output

Load-independent DC current:	0 ... 1 to 0 ... 20 mA resp. live-zero 0.2 ... 1 to 4 ... 20 mA ± 1 to ± 20 mA
Burden voltage:	+ 15 V, resp. - 12 V
Load-independent DC voltage:	0 ... 1 to 0 ... 10 V resp. live-zero 0.2 ... 1 to 2 ... 10 V ± 1 to ± 10 V
Load capacity:	Max. 4 mA
Voltage limit under $R_{ext} = \infty$:	≤ 25 V
Current limit under overload:	Approx. 30 mA
Residual ripple in output current:	$< 0.5\%$ p.p.
Nominal value of response time:	4 periods of the nominal frequency
Other ranges:	2, 8 or 16 periods of the nominal frequency

Output characteristic

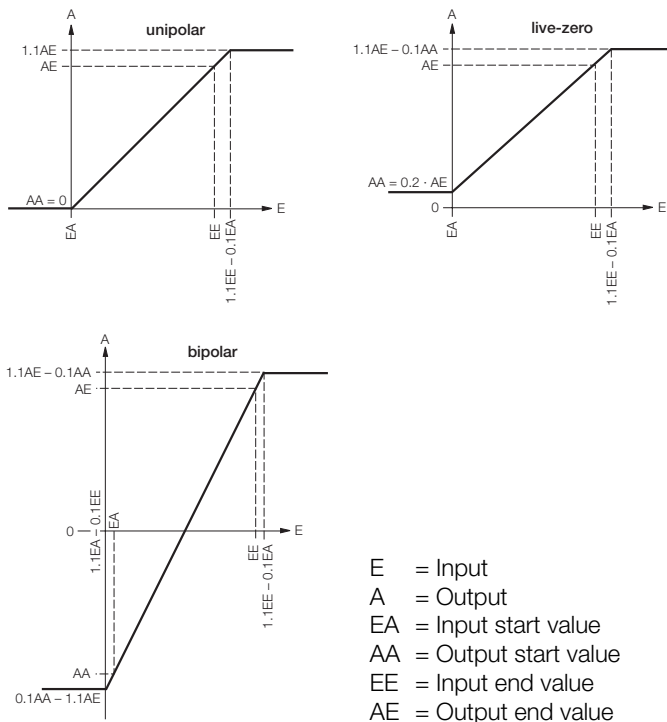

Accuracy (acc. to IEC 688)

Reference value:	$\Delta\varphi = 90^\circ$ resp. $\Delta \cos\varphi = 0.5$
Basic accuracy:	Class 0.5

Reference conditions:

Ambient temperature	15 ... 30 °C
Input current	0.8 ... 1.2 I_N
Input voltage	0.8 ... 1.2 U_N
Frequency	$f_N \pm 10\%$
Wave forms	Sine wave
Power supply	At nominal range
Output burden	ΔR_{ext} max.

Additional errors (maxima):

Voltage influence between 0.5 and 1.5 U_N	$\pm 0.3\%$
Current influence	
– between 0.4 and 1.5 I_N	$\pm 0.3\%$
– between 0.1 and 1.5 I_N	$\pm 0.5\%$

Safety

Protection class:	II (protection isolated, EN 61 010)
Pollution degree:	2
Installation category:	III
Rated insulation voltage (against earth):	230 V resp. 400 V, inputs 230 V, power supply 40 V, output
Test voltage:	50 Hz, 1 min. acc. to EN 61 010-1 3700 resp. 5550 V, inputs versus all other circuits 3250 V, input circuits versus each other 3700 V, power supply versus output

Power supply

DC, AC power pack (DC or 40 ... 400 Hz)

Table 1: Rated voltages and permissible variations

Rated voltage	Tolerance
85 ... 230 V DC, AC	DC - 15 ... + 33%
24 ... 60 V DC, AC	AC $\pm 15\%$

or

Power supply from voltage measuring input:	24 ... 60 V AC or 85 ... 230 V AC
Power consumption:	Approx. 2 W resp. 4 VA

Installation data

Mechanical design:	Plug-in module for 19" rack-mounted case, Euro format 100 x 160 mm
Space requirements:	7 TE (35.26 mm) (see section "Dimensional drawing")
Front plate colour:	Grey RAL 7032

Designation:	EURAX G 536
Mounting position:	Any
Electrical connections:	32-pole plug acc. to DIN 41 612, pattern F and 2-pole current plug Contact fitting see section "Electrical connections"
Coding:	By coding pins, removed / not re- moved, see section "Electrical con- nections"
Weight:	Approx. 0.24 kg

Ambient tests

En 60 068-2-6:	Vibration
Acceleration:	± 2 g
Frequency range:	10 ... 150 ... 10 Hz, rate of frequency sweep: 1 octave / minute
Number of cycles:	10, in each of the three axes
EN 60 068-2-27:	Shock
Acceleration:	3 × 50 g, 3 shocks each in 6 directions
EN 60 068-2-1/-2/-3:	Cold, dry heat, damp heat

Environmental conditions

Operating temperature:	- 10 to +55 °C
Storage temperature:	- 40 to +70 °C
Relative humidity of annual mean:	≤ 75%

Table 2: Specification and ordering information

Order Code 536 -						
Features, Selection	*SCODE	no-go				
1. Mechanical design 2) Plug-in module for 19" rack-mounted case			2	.	.	.
2. Measuring mode 1) For phase angle (φ -linear) 2) For power factor ($\cos\varphi$ -linear)	A B		.	1	.	.
3. Application 1) Single-phase AC 2) U: L1 & L2 I: L1 3 or 4-wire 3-phase balanced load 3) U: L2 & L3 I: L2 3 or 4-wire 3-phase balanced load 4) U: L3 & L1 I: L3 3 or 4-wire 3-phase balanced load 5) U: L1 & L3 I: L1 3 or 4-wire 3-phase balanced load 6) U: L2 & L1 I: L2 3 or 4-wire 3-phase balanced load 7) U: L3 & L2 I: L3 3 or 4-wire 3-phase balanced load A) U: L1 & L2 I: L3 3 or 4-wire 3-phase balanced load B) U: L2 & L3 I: L1 3 or 4-wire 3-phase balanced load C) U: L3 & L1 I: L2 3 or 4-wire 3-phase balanced load			.	.	1	
4. Nominal input frequency 1) 50 Hz 2) 60 Hz 9) Non-standard [Hz] ≥ 10 to 400 Hz With power supply from measuring input min. 40 Hz			.	.	.	1
			.	.	.	2
			.	.	.	9

Continuation of "Table 2: Specification and ordering information" see on next page!

EURAX G 536

Phase angle or power factor transducer

Continuation of "Table 2: Specification and ordering information"!

Order Code 536 -									
Features, Selection	*SCODE	no-go							
5. Nominal input voltage									
1) $U_N = 100$ V	C							1
2) $U_N = 230$ V	C							2
3) $U_N = 400$ V	D							3
9) Non-standard [V] <input type="text"/>								9
≥ 10 to 690 With power supply from measuring input min. 24 V, max. 230 V, see feature 9, lines 3 and 4									
3 phase system: Input voltage = phase to phase voltage									
6. Nominal input current									
1) 1 A								. 1
2) 5 A								. 2
9) Non-standard [A] <input type="text"/>								. 9
≥ 0.5 to 6.0									
7. Measuring range									
1) Phase angle $-60 \dots 0 \dots +60$ °el								. . 1
2) $\cos\varphi$ 0,5 ... cap ... 1 ... ind ... 0,5								. . 2
9) Non-standard [°el] or [cosφ] <input type="text"/>								. . 9
Measuring range within $-180 \dots 0 \dots +180$ °el or $-1 \dots \text{ind} \dots 0 \dots \text{cap} \dots 1 \dots \text{ind} \dots 0 \dots \text{cap} \dots -1$, but clear indication only to $-175 \dots 0 \dots +175$ °el Measuring span ≥ 20 °el									
8. Output signal									
1) 0 ... 20 mA								. . . 1
2) 4 ... 20 mA								. . . 2
9) Non-standard [mA] <input type="text"/>								. . . 9
0 ... 1.00 to 0 ... < 20, $-1.00 \dots 0 \dots 1.00$ to $-20 \dots 0 \dots 20$ (symmetrical) 0.2 ... 1 to < (4 ... 20) (AA / AE = 1 / 5)									
A) 0 ... 10 V								. . . A
Z) Non-standard [V] <input type="text"/>								. . . Z
0 ... 1.00 to 0 ... < 10, $-1.00 \dots 0 \dots 1.00$ to $-10 \dots 0 \dots 10$ (symmetrical) 0.2 ... 1 to 2 ... 10 (AA / AE = 1 / 5)									
AA = Output start value, AE = Output end value									
9. Power supply									
1) 85 ... 230 V DC, AC							 1
2) 24 ... 60 V DC, AC							 2
3) Internal from measuring input (24 ... 60 V AC)							 3
4) Internal from measuring input (85 ... 230 V AC)							 4

Continuation of "Table 2: Specification and ordering information" see on next page!

Continuation of "Table 2: Specification and ordering information"!

Order Code 536 -																					
Features, Selection											*SCODE	no-go									
10. Response time																					
1) 4 periods of the nominal input frequency (Standard)																				1	
2) 2 periods of the nominal input frequency																				2	
3) 8 periods of the nominal input frequency																				3	
4) 16 periods of the nominal input frequency																				4	
11. Test certificate																					
0) Without test certificate																					. 0
D) Test certificate in German																					. D
E) Test certificate in English																					. E

* Lines with letter(s) under "no-go" cannot be combined with preceding lines having the same letter under "SCODE".

Application notes

Current connection in phase	L1	L2	L3	L1	L2	L3
Voltage connection between:	L1 & L2	L2 & L3	L3 & L1	L1 & L3	L2 & L1	L3 & L2
Vector diagrams						

Current connection in phase	L3	L1	L2	L
Voltage connection between:	L1 & L2	L2 & L3	L3 & L1	L & N
Vector diagrams				

EURAX G 536

Phase angle or power factor transducer

Electrical connections

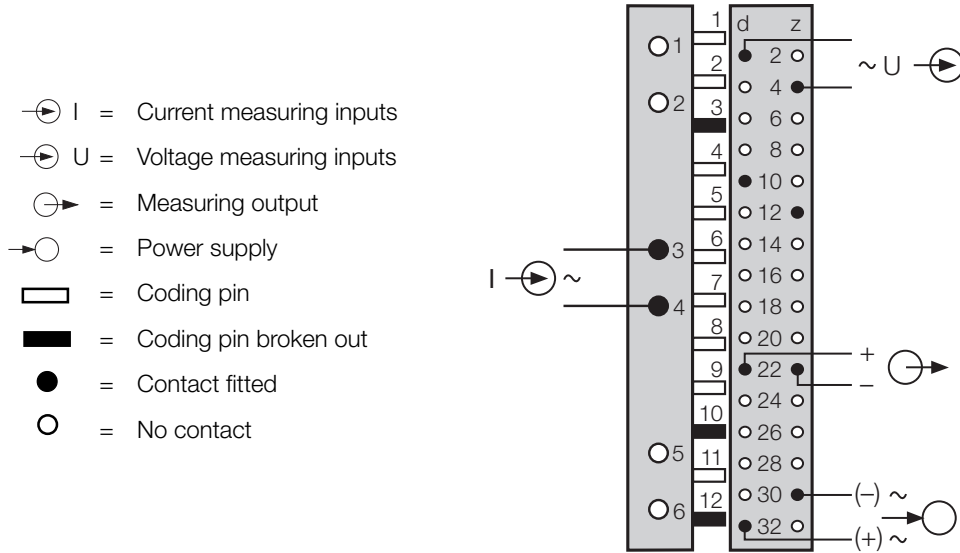

Measuring inputs

Application	Plug wiring	Application	Plug wiring
Phase angle or power factor measurement in single-phase AC network		Phase angle or power factor measurement in 3 or 4-wire 3-phase network U: L1 & L2 I: L1	
Phase angle or power factor measurement in 3 or 4-wire 3-phase network U: L2 & L3 I: L2		Phase angle or power factor measurement in 3 or 4-wire 3-phase network U: L3 & L1 I: L3	
Phase angle or power factor measurement in 3 or 4-wire 3-phase network U: L1 & L3 I: L1		Phase angle or power factor measurement in 3 or 4-wire 3-phase network U: L2 & L1 I: L2	
Phase angle or power factor measurement in 3 or 4-wire 3-phase network U: L3 & L2 I: L3		Phase angle or power factor measurement in 3 or 4-wire 3-phase network U: L3 & L1 I: L2	
Phase angle or power factor measurement in 3 or 4-wire 3-phase network U: L2 & L3 I: L1			

Dimensional drawing

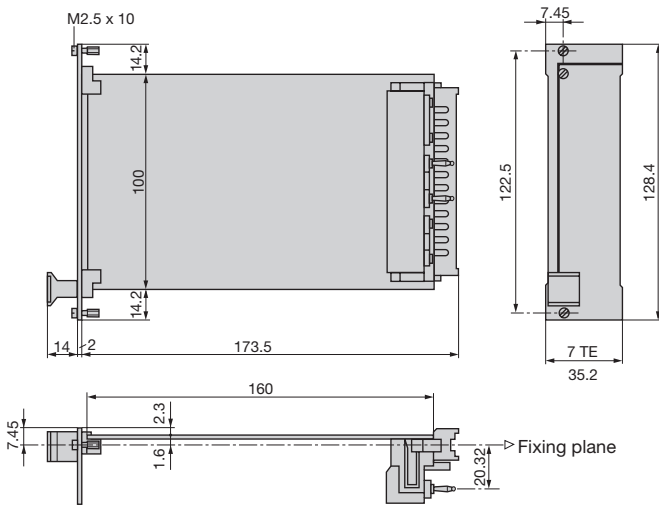

Fig. 2. EURAX G 536, front plate width 7 TE.

EURAX G 536

Phase angle or power factor transducer

Printed in Switzerland • Subject to change without notice • Edition 08.01 • Data sheet No. G 536-2 Le

Aargauerstrasse 7
CH-5610 Wohlen/Switzerland
Phone +41 56 618 21 11
Fax +41 56 618 24 58
e-mail: cbag@gmc-instruments.com
<http://www.gmc-instruments.com>

Camille Bauer Ltd

GOSSEN
METRAWATT
CAMILLE BAUER 